

Assimétrica

Aparador/Buffer

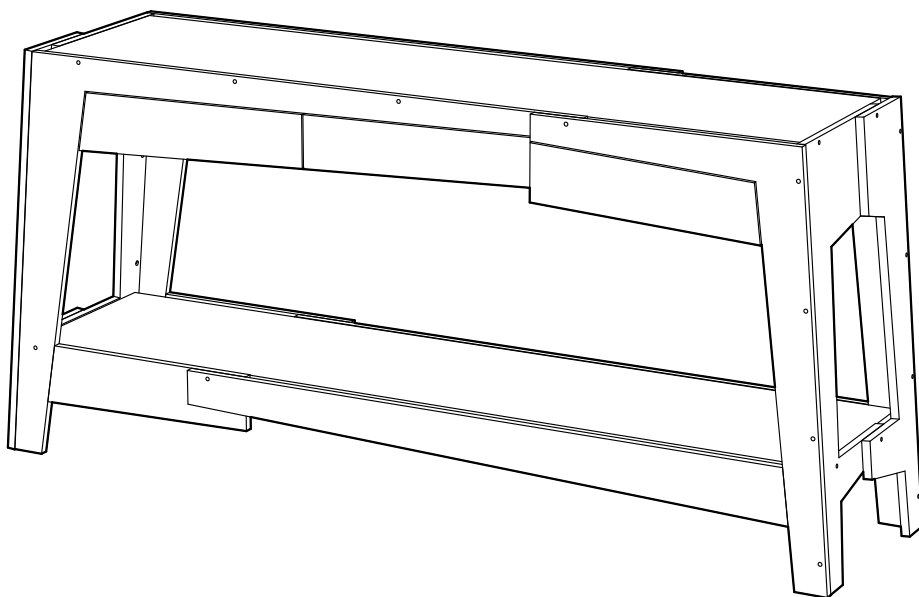

Não utilizar parafusadeira
na montagem



Bem-vindo

A Tok&Stok traz até você soluções práticas de design com manuais de montagem e instalação detalhados para possibilitar o pleno aproveitamento do potencial dos produtos.

Para assegurar a garantia, é recomendada a prévia conferência de partes e componentes, bem como a leitura dos passos e suas ilustrações.

Preservar este documento é essencial para a adequada manutenção de seu móvel, o que engloba os possíveis ciclos de montagem e desmontagem.

Em casos de dúvidas, o setor de Contact Center atende pelo 0800 70 10 161 de segunda à sexta, das 9:00h às 20:00h, e aos sábados, das 9:00h às 18:00h. Há canais de comunicação também no site www.tokstok.com.br.

Recomendações

Para a montagem deste produto, são necessárias 2 pessoas.

Evitar batidas e o contato com objetos cortantes.

Observar as cargas máximas suportáveis, quando houver, conforme o desenho esquemático no final do documento.

Partes do produto protegidas da incidência de luz estão sujeitas a alterações de tonalidade diferentemente das expostas. Somente o uso freqüente pode amenizar esta ocorrência.

Algumas pinturas novas, embora atóxicas, podem apresentar odores. Para amenizá-los, mantenha o móvel em local arejado por aproximadamente três dias.

Manutenção e Limpeza

Pano levemente umedecido com água, seguido de pano seco.

*Nunca utilizar produtos químicos ou abrasivos.

Abaixo sinalizadas, as ferramentas não fornecidas mas necessárias para a montagem do produto.

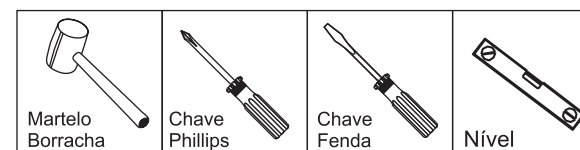





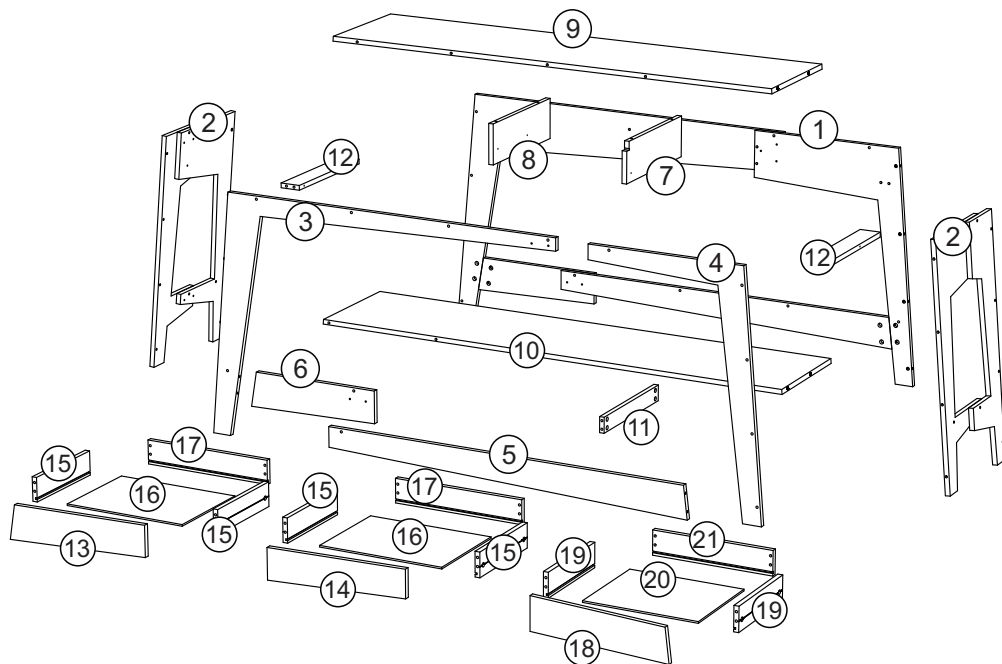





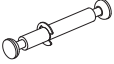

Partes do Produto

- | | |
|---------------------------------|-----------------------------------|
| 1 Pé Traseiro (1x) | <u>Gaveta Esquerda e Central</u> |
| 2 Pé Lateral (2x) | 13 Frente de Gaveta Esquerda (1x) |
| 3 Pé Frontal Esquerdo (1x) | 14 Frente de Gaveta Central (1x) |
| 4 Pé Frontal Direito (1x) | 15 Lateral de Gaveta (4x) |
| 5 Travessa Frontal Maior (1x) | 16 Fundo de Gaveta (2x) |
| 6 Travessa Frontal Menor (1x) | 17 Traseira de Gaveta (2x) |
| 7 Divisão Maior (1x) | <u>Gaveta Direita</u> |
| 8 Divisão Menor (1x) | 18 Frente de Gaveta (1x) |
| 9 Tampo Superior (1x) | 19 Lateral de Gaveta (2x) |
| 10 Tampo Inferior (1x) | 20 Fundo de Gaveta (1x) |
| 11 Travessa Tampo Inferior (1x) | 21 Traseira de Gaveta (1x) |
| 12 Calço Corrediça (2x) | |



Componentes

- | | | | |
|--|--|---|---|
| 
A - Parafuso
Ø1/4"x60 (8x) | 
B - Parafuso
Ø1/4"x40 (28x) | 
C - Parafuso
Ø4,0x30 (4x) | 
D - Parafuso
Ø4,0x14 (24x) |
| 
E - Cavilha
Ø8x30 (12x) | 
F - Haste
Dupla (4x) | 
G - Minifix (32x) | 
H - Tambor (40x) |
| 
I - Porca
Cilíndrica (36x) | 
J - Corrediça
Telescópica (3x) | 
K - Feltro (8x) | 
L - Trapézio
com Parafuso (12x) |
| 
M - Chave
Allen (1x) | 
N - Cola (1x) | | |

Utilizar a régua abaixo para medir os componentes.



medidas em mm

Pré-Montagem

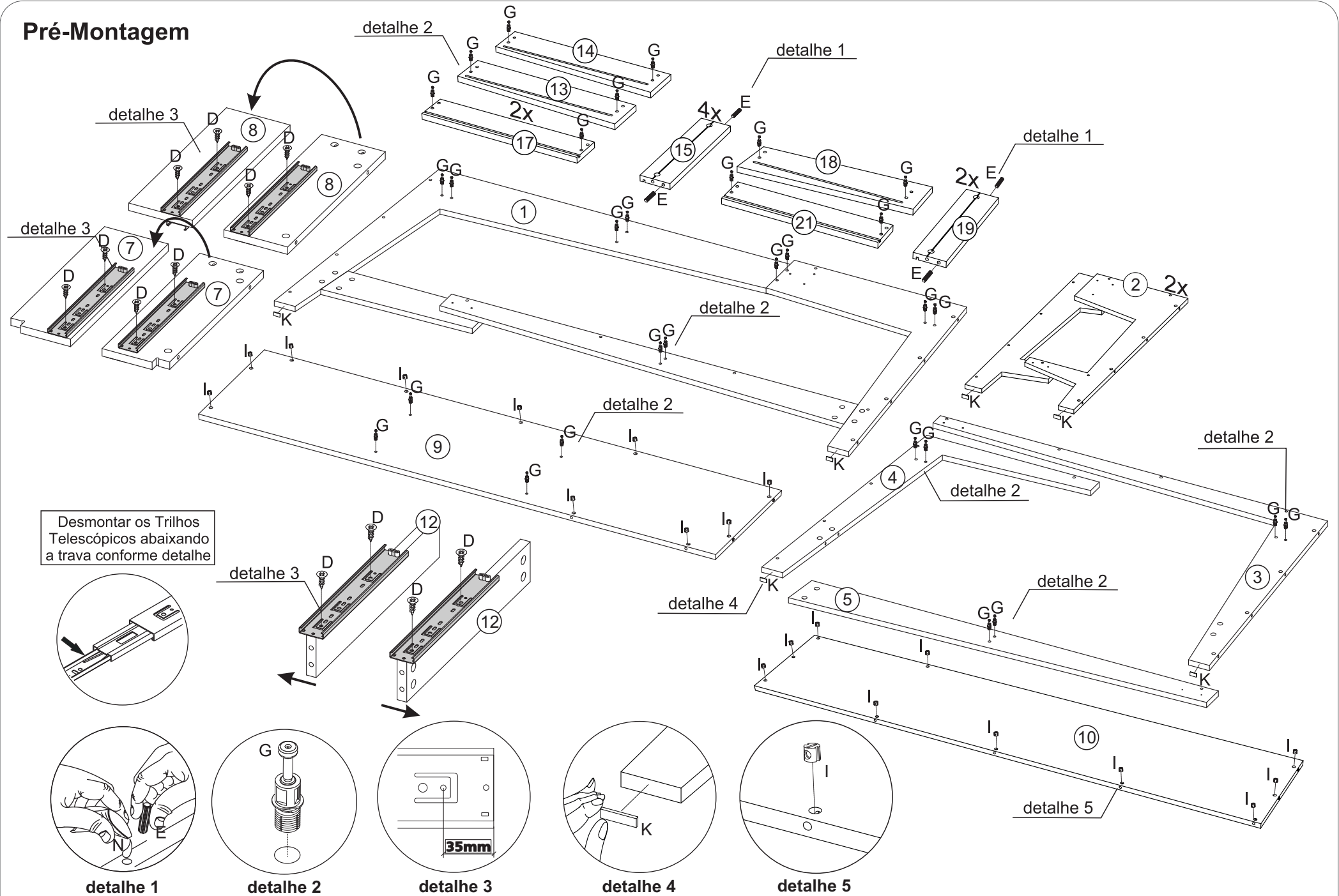

1 Montagem

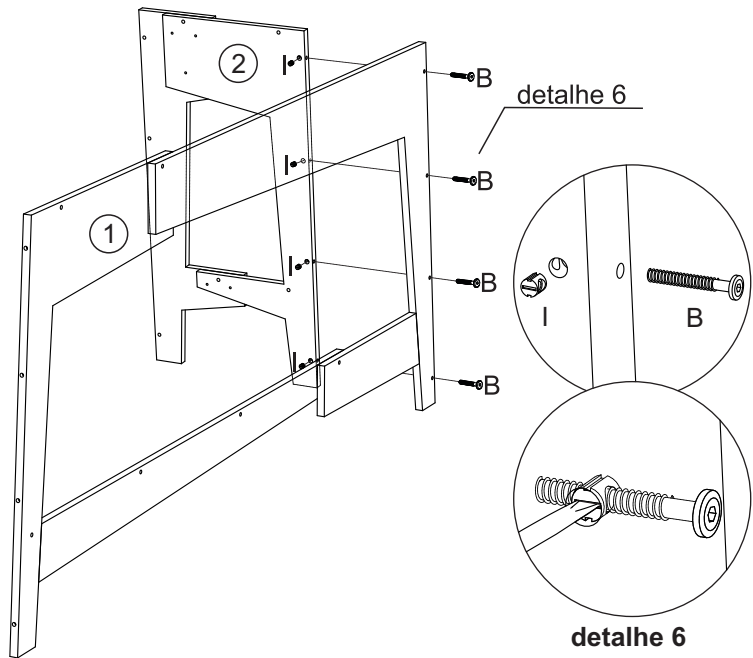
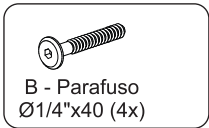

3

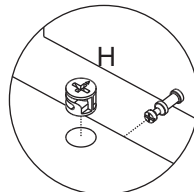
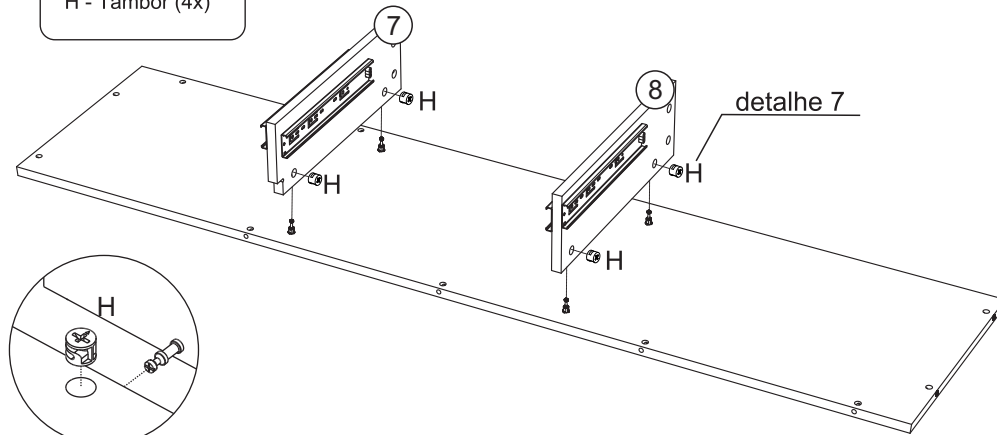
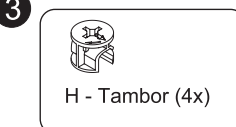

detalhe 7
Encaixar e girar os tambores em sentido horário

2

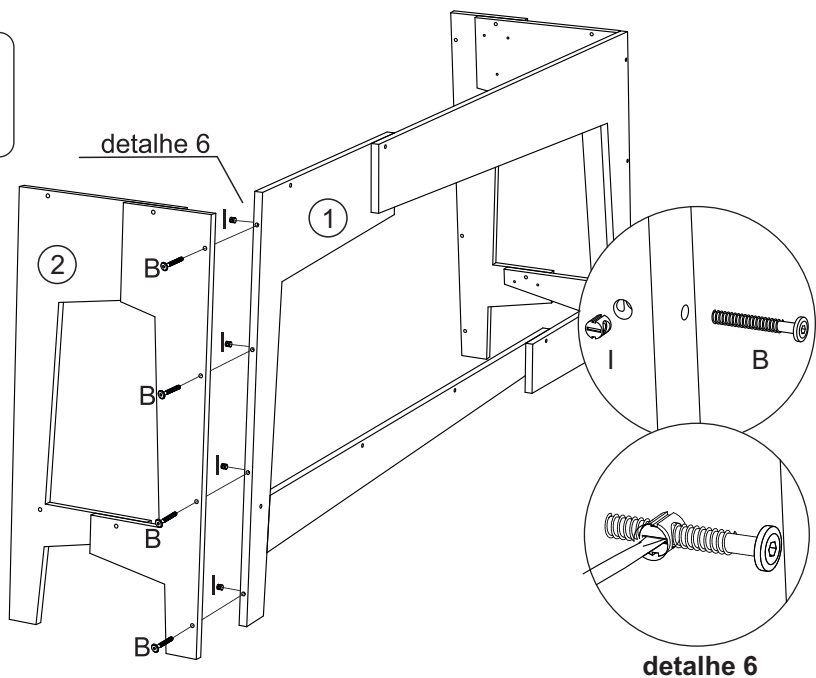
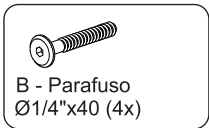

4

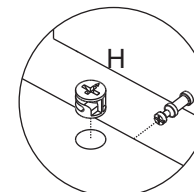
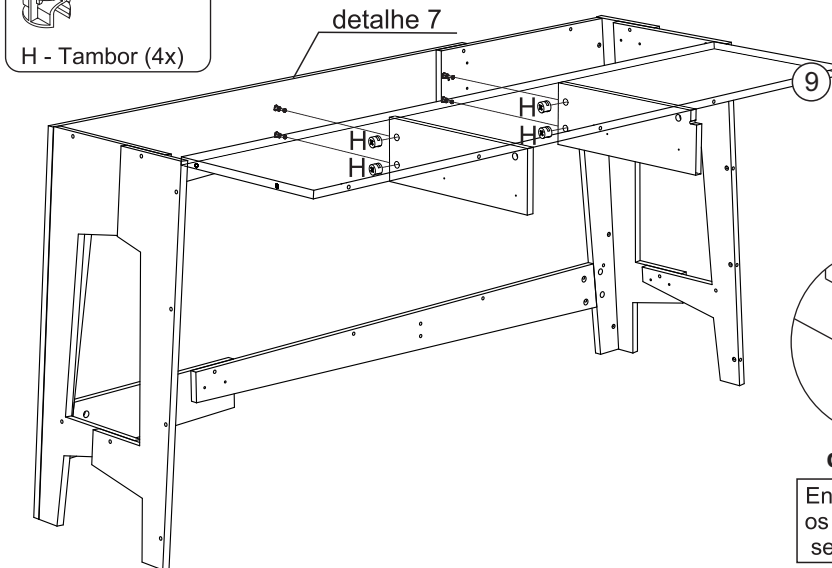

detalhe 7
Encaixar e girar os tambores em sentido horário

5

A - Parafuso
Ø1/4"x60 (3x)

B - Parafuso
Ø1/4"x40 (3x)

detalhe 6

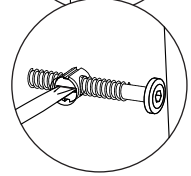
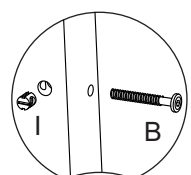

detalhe 6

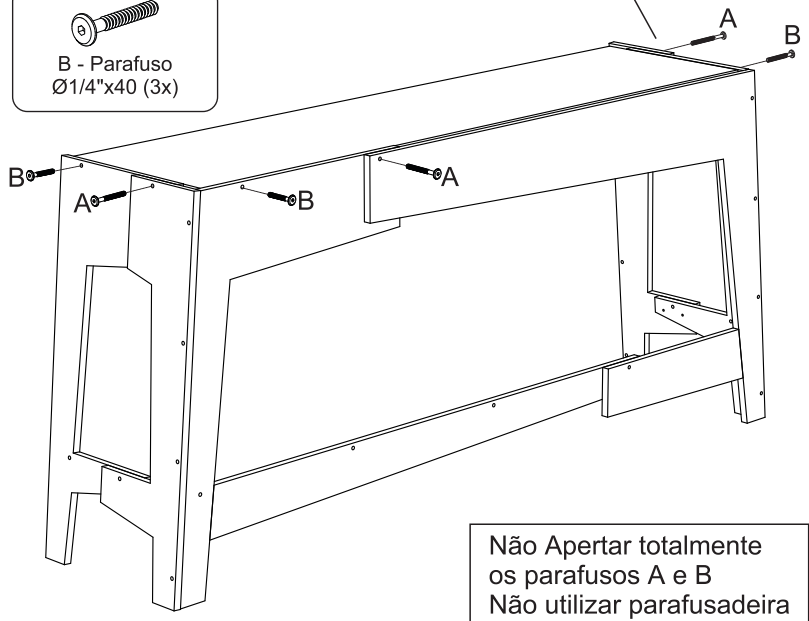

Não Apertar totalmente os parafusos A e B
Não utilizar parafusadeira

7

A - Parafuso
Ø1/4"x60 (2x)

B - Parafuso
Ø1/4"x40 (2x)

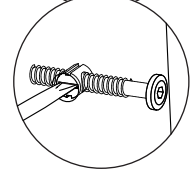
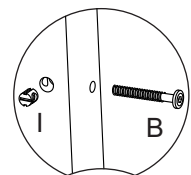

detalhe 6

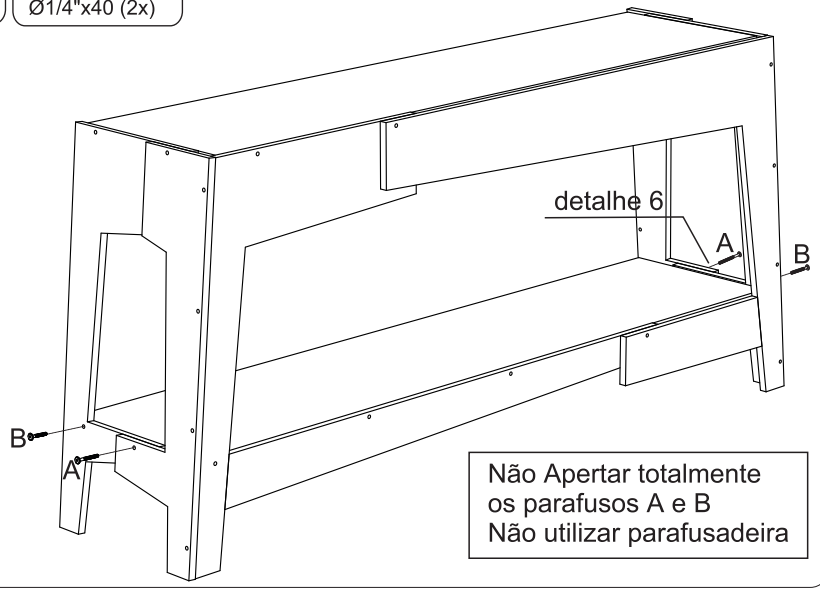

Não Apertar totalmente os parafusos A e B
Não utilizar parafusadeira

6

A - Parafuso
Ø1/4"x60 (1x)

B - Parafuso
Ø1/4"x40 (3x)

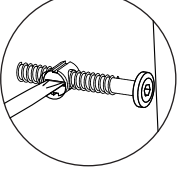
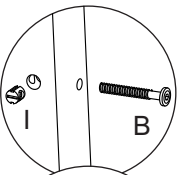

detalhe 6

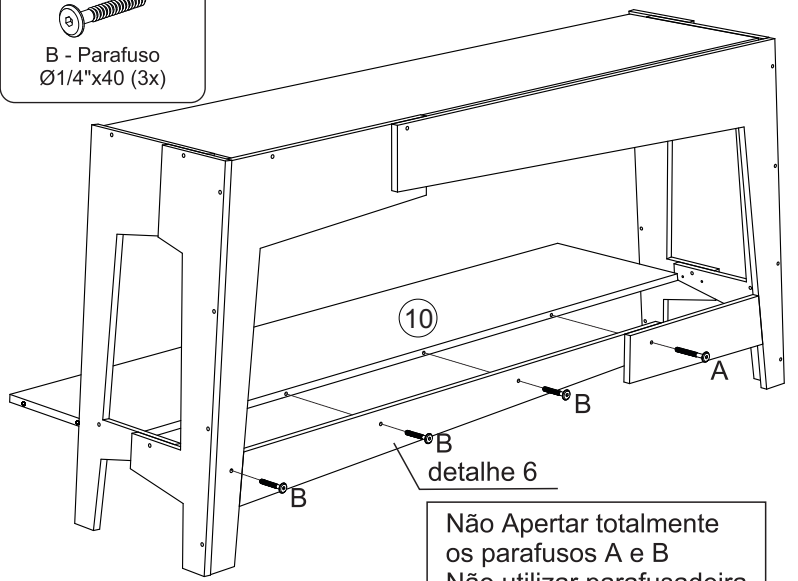

Não Apertar totalmente os parafusos A e B
Não utilizar parafusadeira

8

H - Tambor (6x)

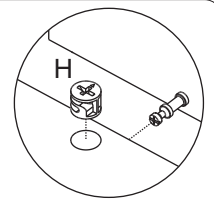

detalhe 7

Encaixar e girar os tambores em sentido horário

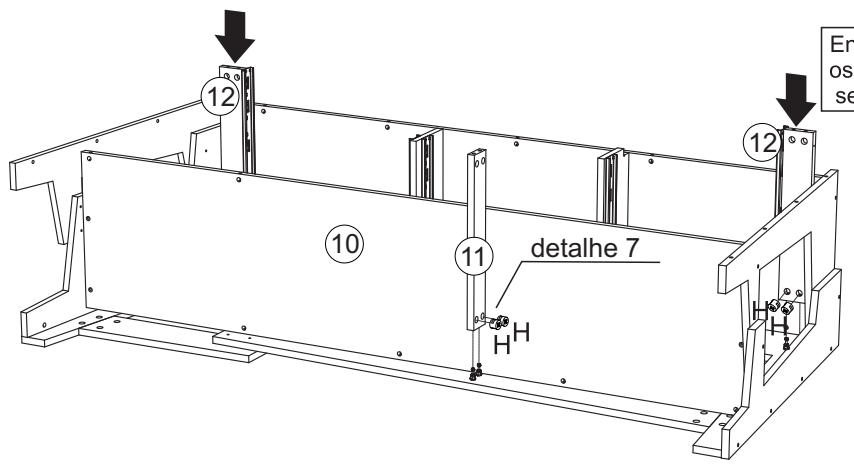

9

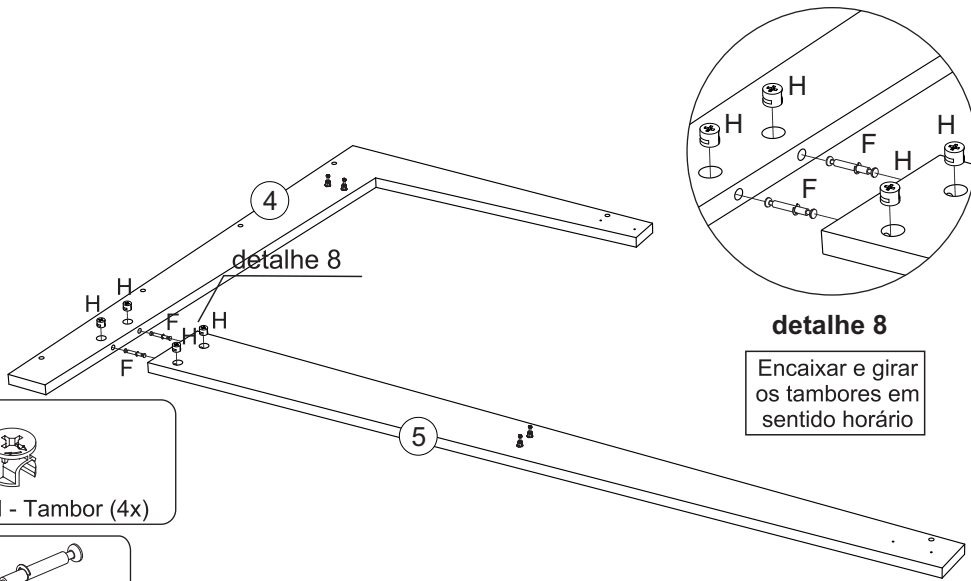

H - Tambor (4x)

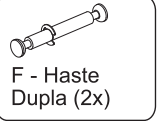

F - Haste Dupla (2x)

detalhe 8

Encaixar e girar os tambores em sentido horário

11

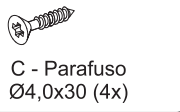

C - Parafuso Ø4,0x30 (4x)

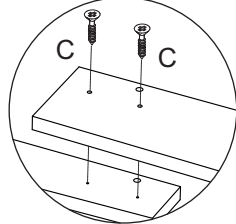
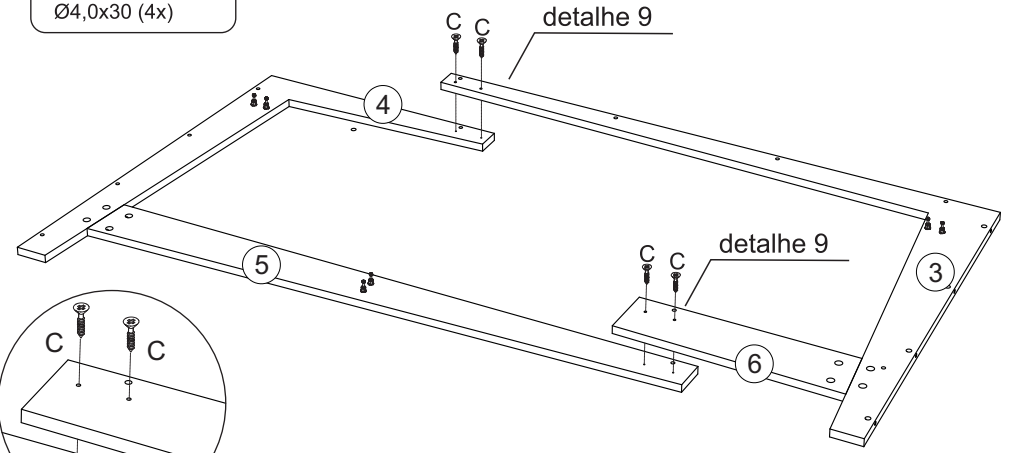

detalhe 9

10



H - Tambor (4x)

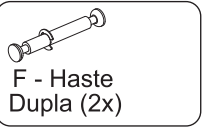

F - Haste Dupla (2x)

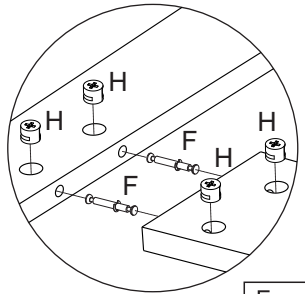

detalhe 8

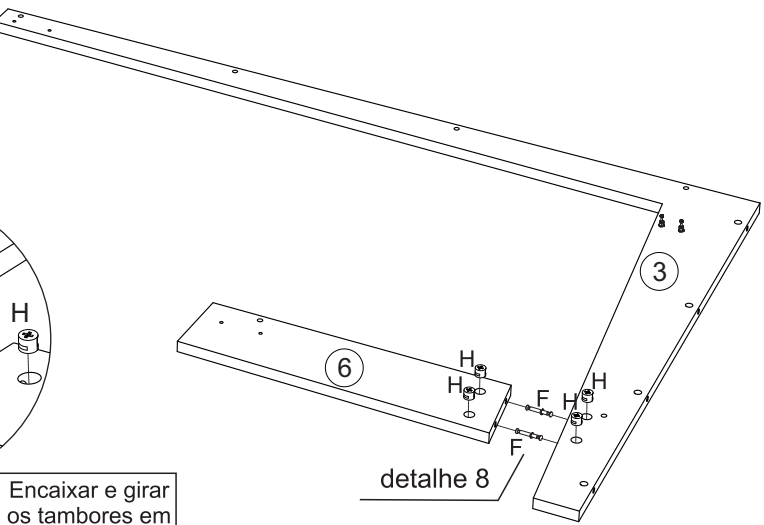

Encaixar e girar os tambores em sentido horário

12



A - Parafuso Ø1/4"x60 (2x)



B - Parafuso Ø1/4"x40 (8x)



H - Tambor (6x)



I - Porca Cilíndrica (4x)

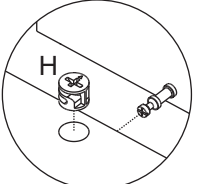

detalhe 7

Encaixar e girar os tambores em sentido horário

Não Apertar totalmente os parafusos A e B
Não utilizar parafusadeira

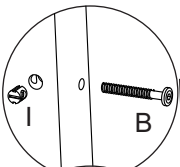

detalhe 6

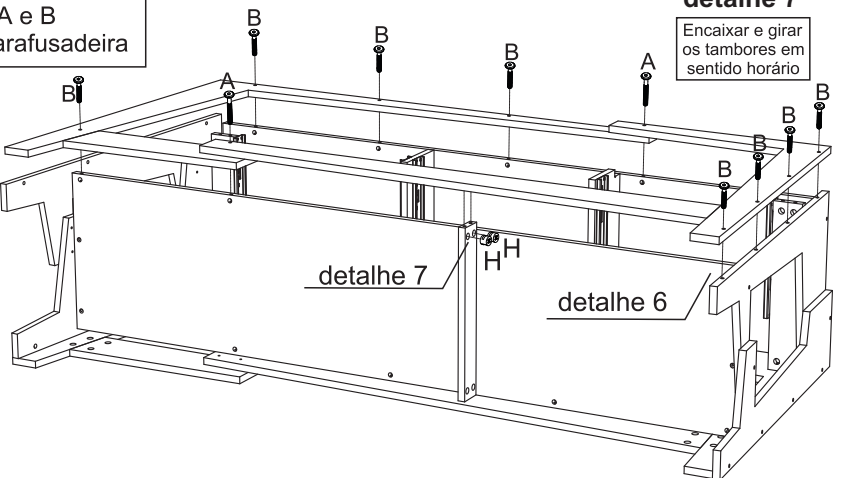

13

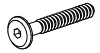

B - Parafuso
Ø1/4"x40 (4x)



I - Porca
Cilíndrica (4x)

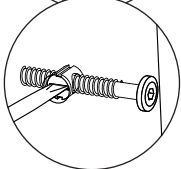
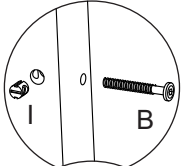

detalhe 6

detalhe 6

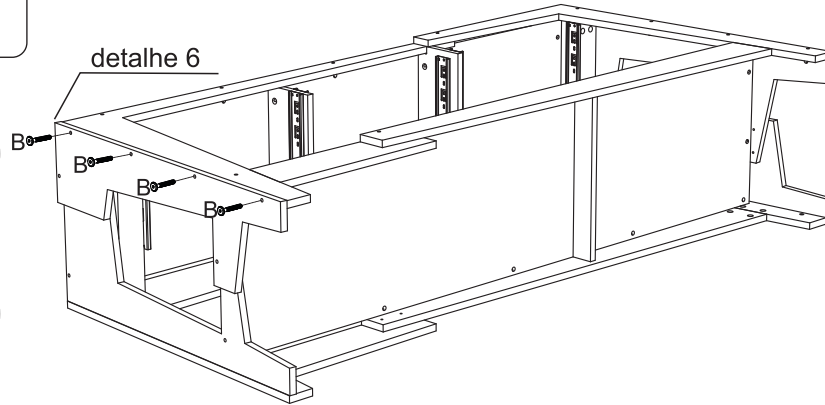

14

Nivelar as peças e
apertar totalmente
os parafusos A e B
Não utilizar parafusadeira

detalhe 10

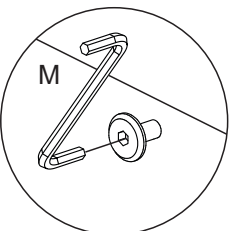
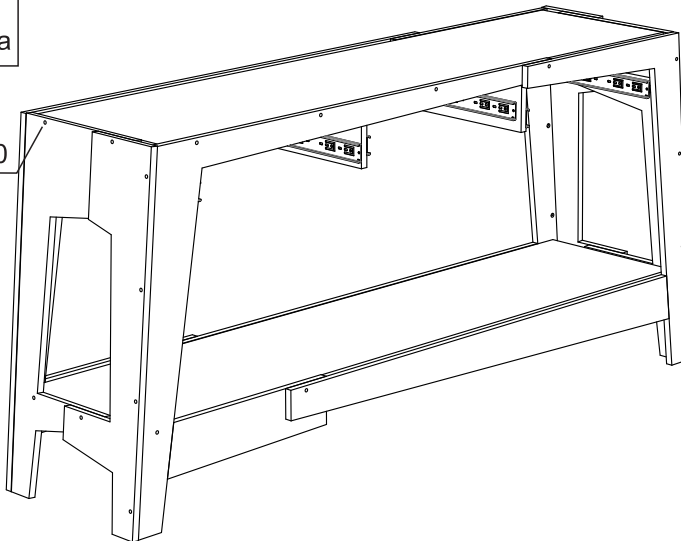

detalhe 10

15



D - Parafuso
Ø4,0x14 (8x)



H - Tambor (8x)



L - Trapézio
com Parafuso (8x)



J - Corrediça
Telescópica (2x)

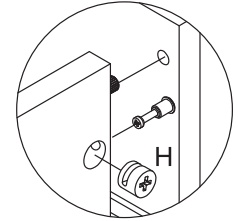
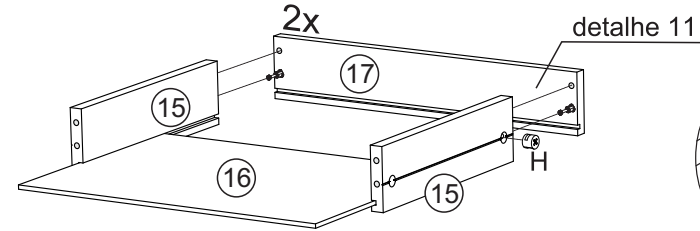

detalhe 11

Encaixar e girar
os tambores em
sentido horário

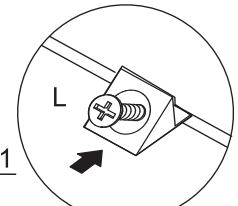
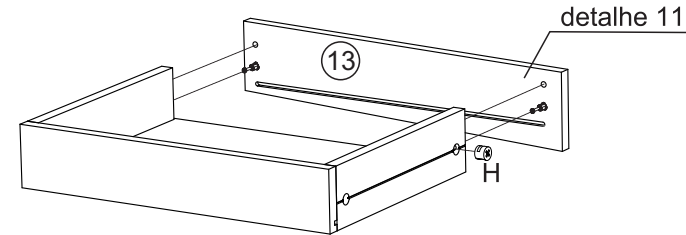

detalhe 12

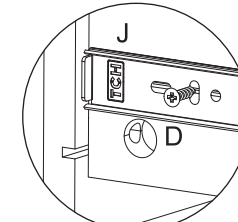
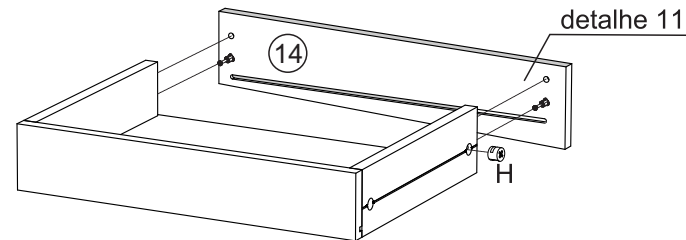

detalhe 13

Alinhar a Corrediça
(J) com a Frente
de gaveta

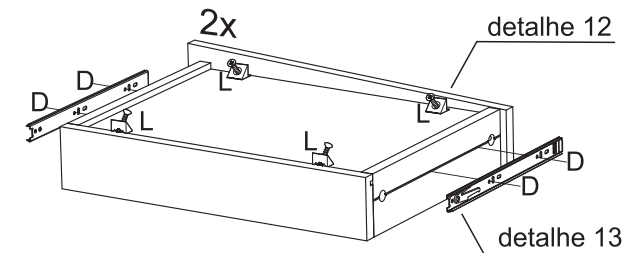

detalhe 13

16



D - Parafuso
Ø4,0x14 (4x)



H - Tambor (4x)



L - Trapézio
com Parafuso (4x)



J - Corrediça
Telescópica (1x)

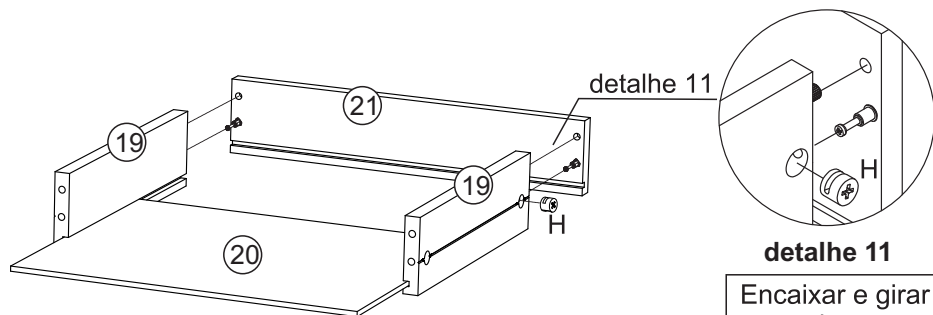

detalhe 11

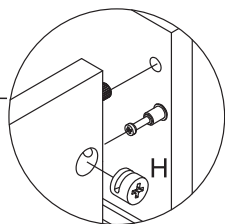

detalhe 11

Encaixar e girar
os tambores em
sentido horário

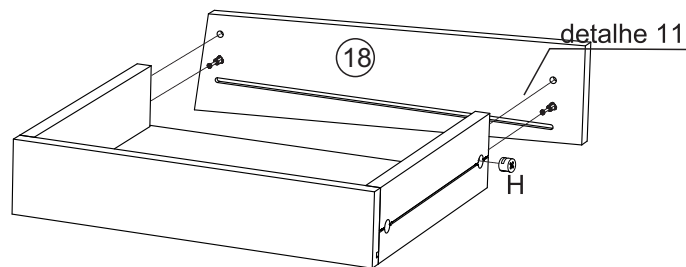

detalhe 11

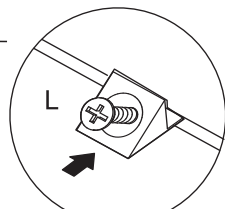

detalhe 12

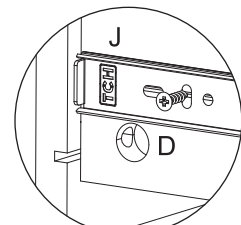

detalhe 13

Alinhar a Corrediça
(J) com a Frente
de gaveta

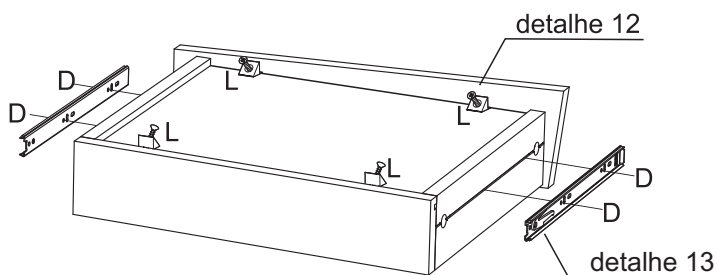

detalhe 12

detalhe 13

17

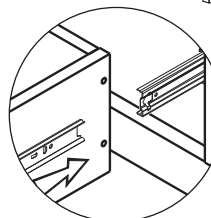
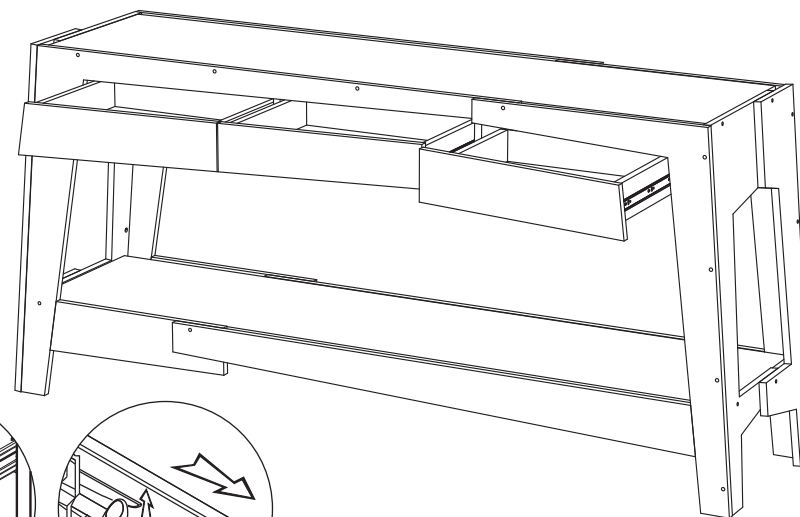

Como encaixar
as gavetas

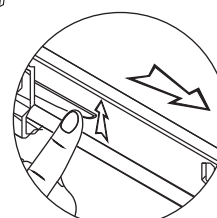

Como tirar
as gavetas

Capacidade de Carga

(distribuídos uniformemente)

