

lin

mesa de cabeceira 1 gaveta
TOK&STOK

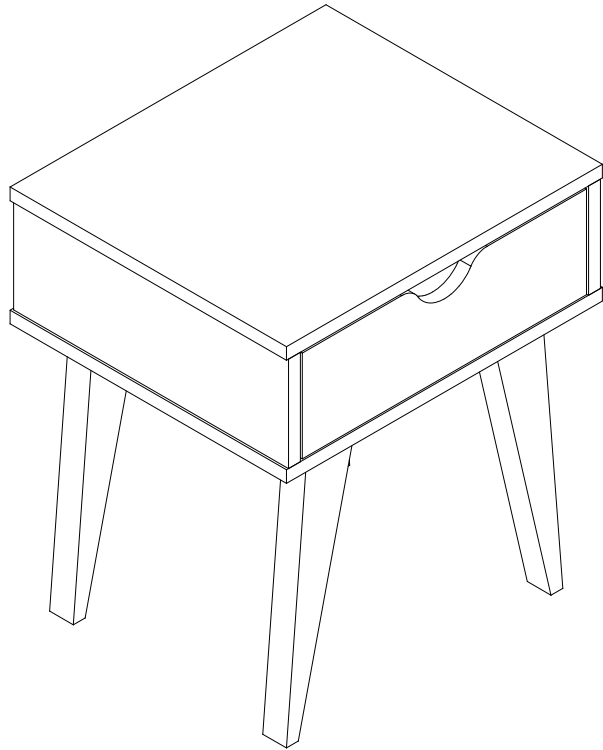

ferramentas necessárias (não fornecidas)



chave phillips



martelo



parafusadeira



1
pessoas necessárias
para montar
o produto



20min
tempo de montagem
aproximado



médio
grau de
dificuldade



não utilizar químicos
ou abrasivos
na limpeza



evitar batidas
e contato com
objetos cortantes









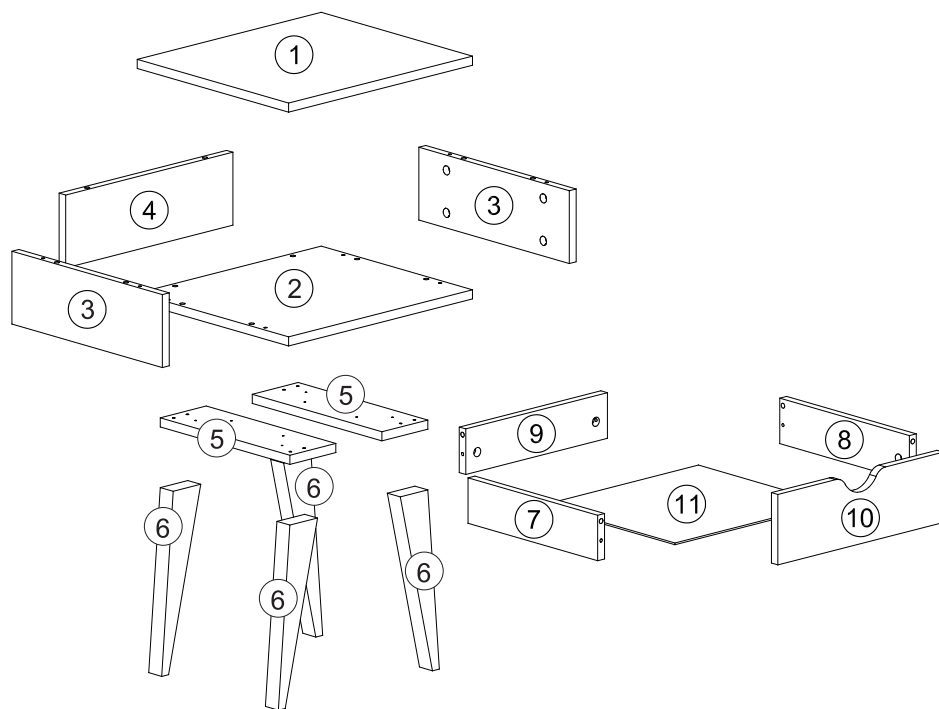

Pano levemente umedecido
com água, seguido de pano
seco.

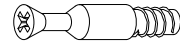
Partes do Produto

- 1** Tampo (1x)
- 2** Base (1x)
- 3** Lateral Esquerda/Direita (2x)
- 4** Fundo (1x)
- 5** Travessa (2x)
- 6** Pé (4x)
- 7** Lateral Esquerda da Gaveta (1x)
- 8** Lateral Direita da Gaveta (1x)
- 9** Fundo da Gaveta (1x)
- 10** Frente de Gaveta (1x)
- 11** Base da Gaveta (1x)

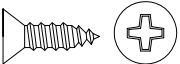

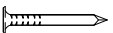
Componentes

-  A- Cavilha 8x30 (16x)
-  B- Minifix (12x)
-  C- Tambor (12x)
-  D- Tapa Furo Adesivo (12x)
-  E- Corrediça Lateral (2x)
-  F- Corrediça da Gaveta (2x)
-  G- Parafuso Ø4x14 (8x)
-  H- Parafuso Ø4x25 (8x)
-  I- Parafuso Ø4x40 (8x)
-  J- Prego (11x)
-  K- Cola (1x)

Utilizar a régua abaixo para medir os componentes.



Pré-Montagem

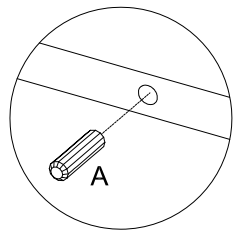
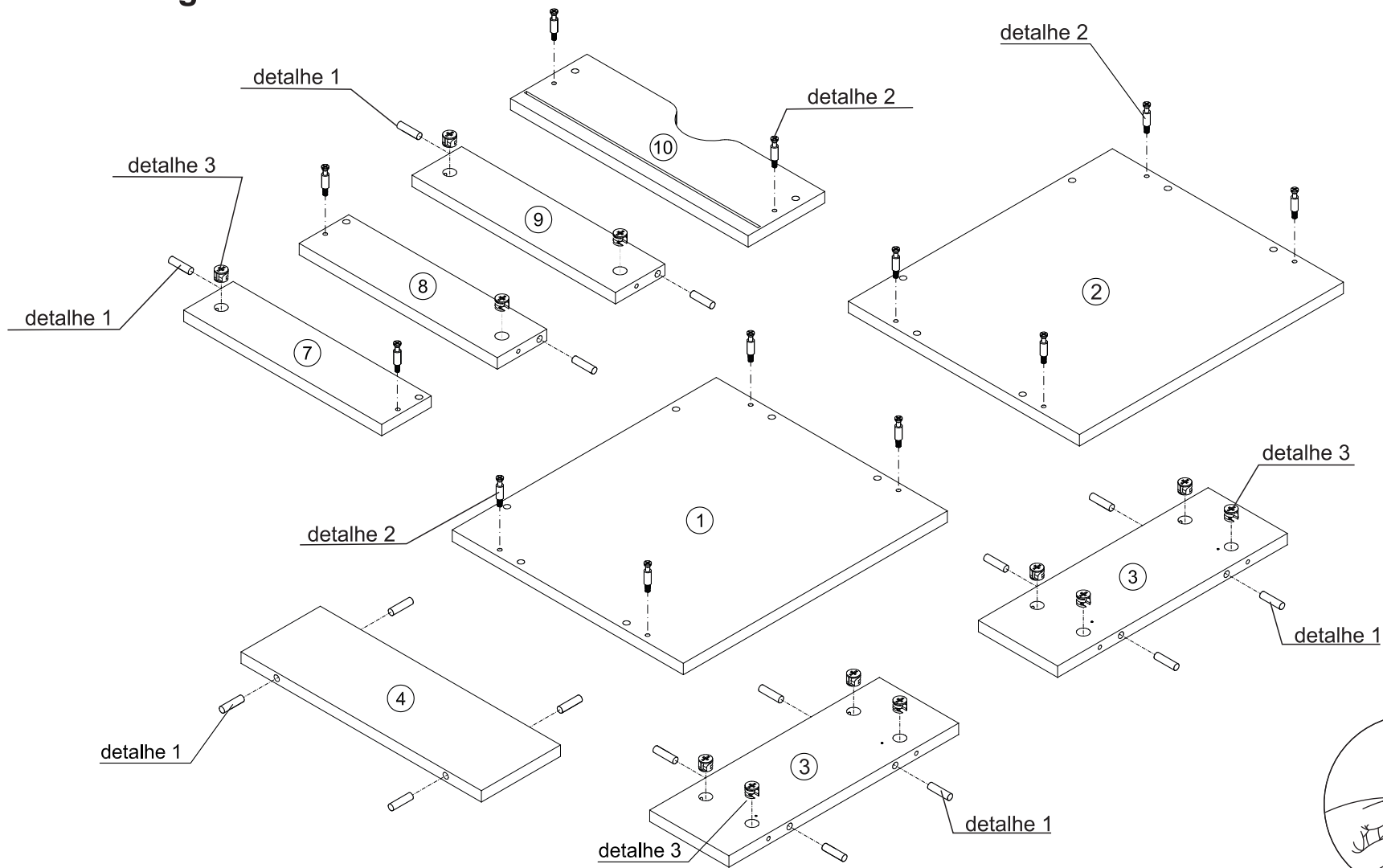

detalhe 1

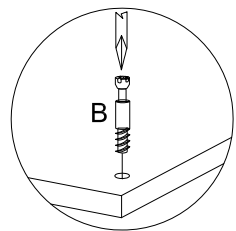

detalhe 2

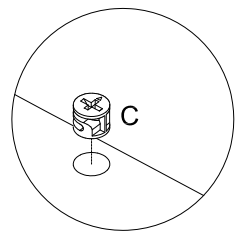

detalhe 3

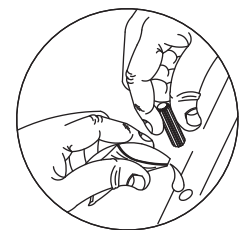

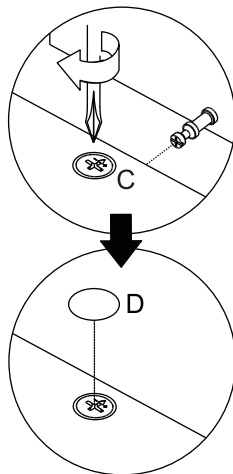
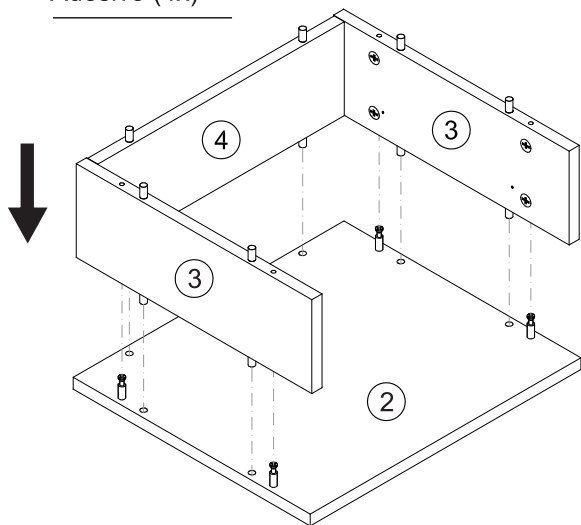

utilizar a cola nas cavilhas das frentes de gaveta.

1 ○
D- Tapa Furo
Adesivo (4x)

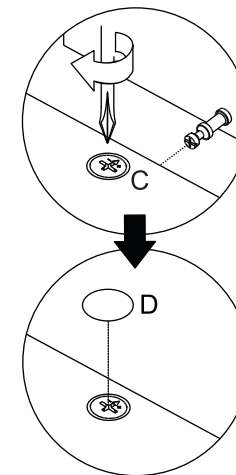
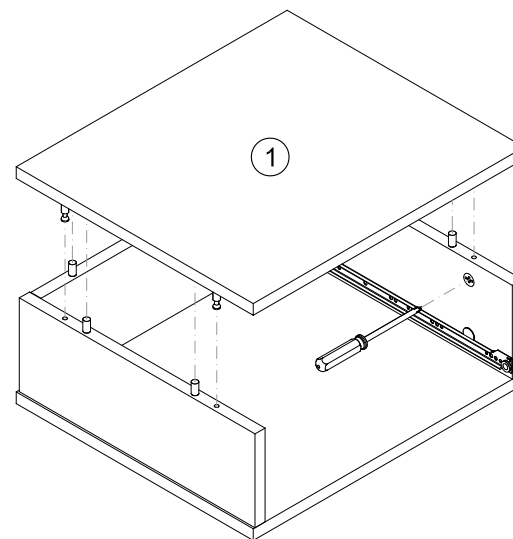

3 ○
D- Tapa Furo
Adesivo (4x)



2 ⚙️ +  + 
G- Parafuso
ø4x14 (4x) | E- Corrediça
Lateral (2x)

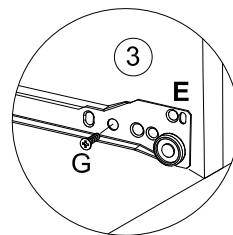
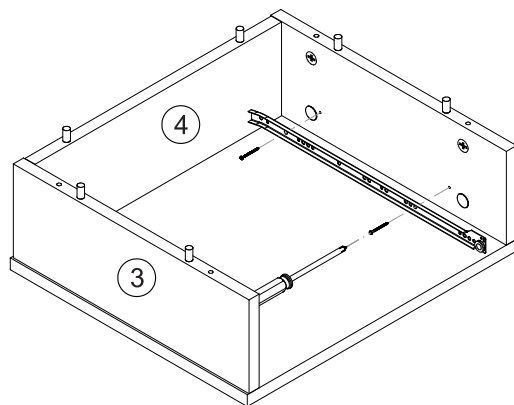

4 ⚙️ + 
I- Parafuso ø4x40 (8x)

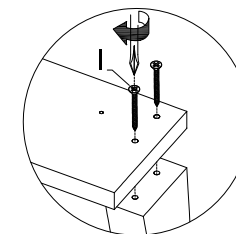
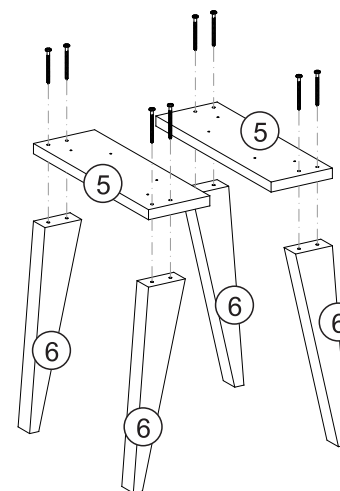

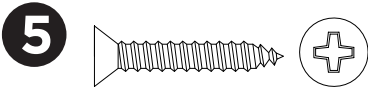

H- Parafuso
ø4x25 (8x)

Centralizar na
marcação existente
e fixar os pés.

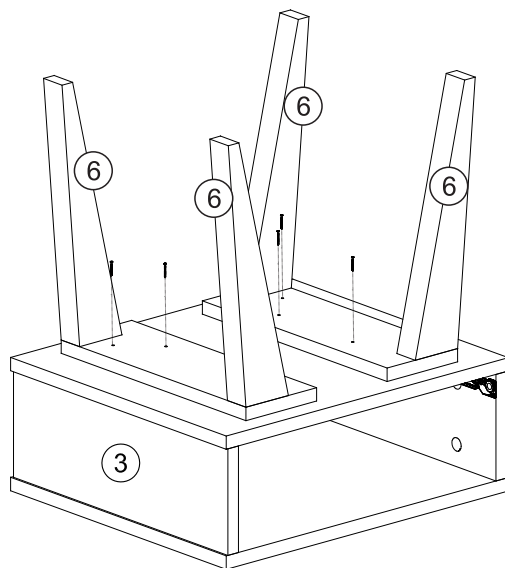
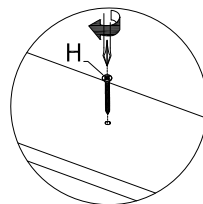
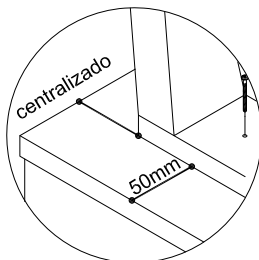

6 D- Tapa Furo
Adesivo (2x)

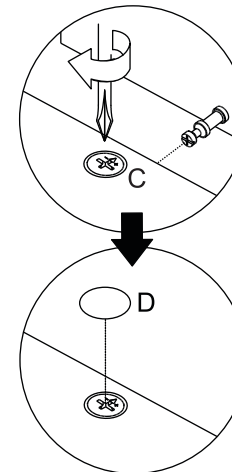
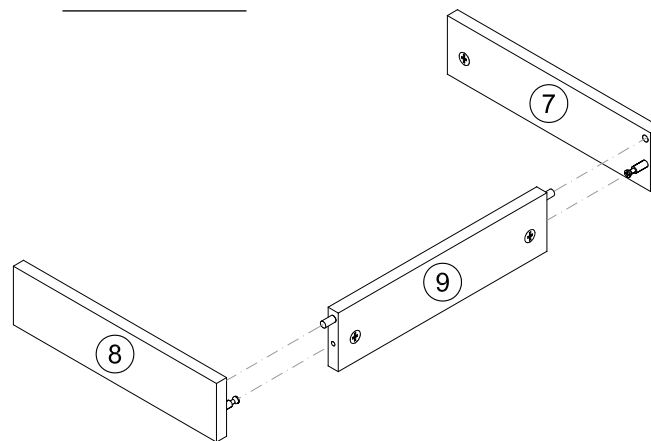

7 D- Tapa Furo
Adesivo (2x)

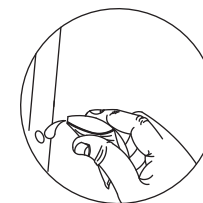

utilizar a cola
nas cavilhas das
frentes de gaveta.

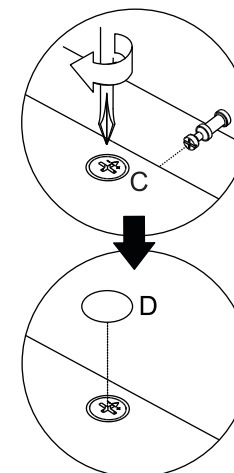
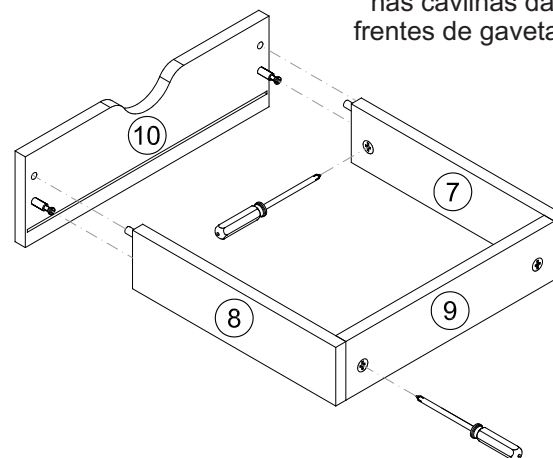

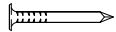
8

J- Prego (11x)

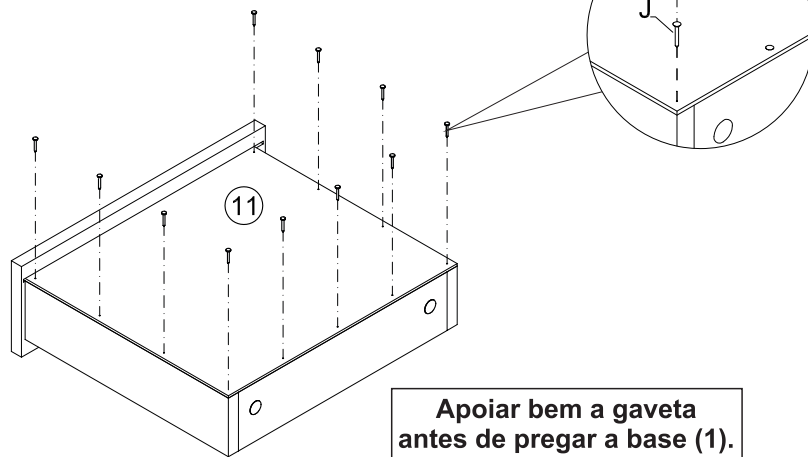
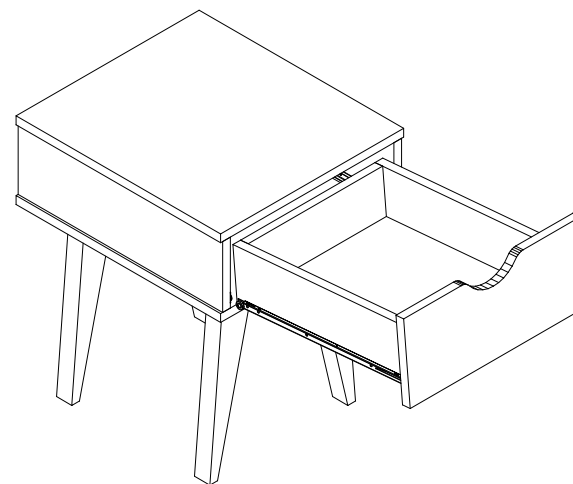
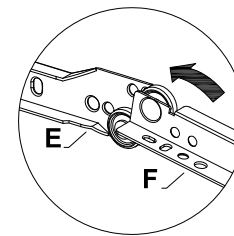
**10****9**

F- Corrediça da Gaveta (2x)

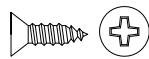

G- Parafuso ø4x14 (4x)

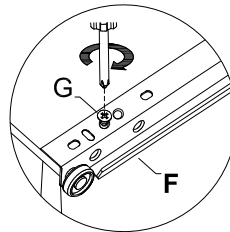
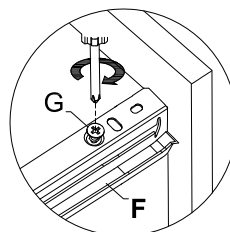
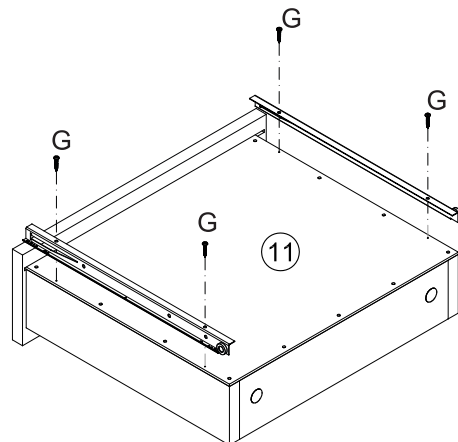

**capacidade de carga
(distribuídos uniformemente)**

